

Daylab 35 Slide Printer

from Polaroid

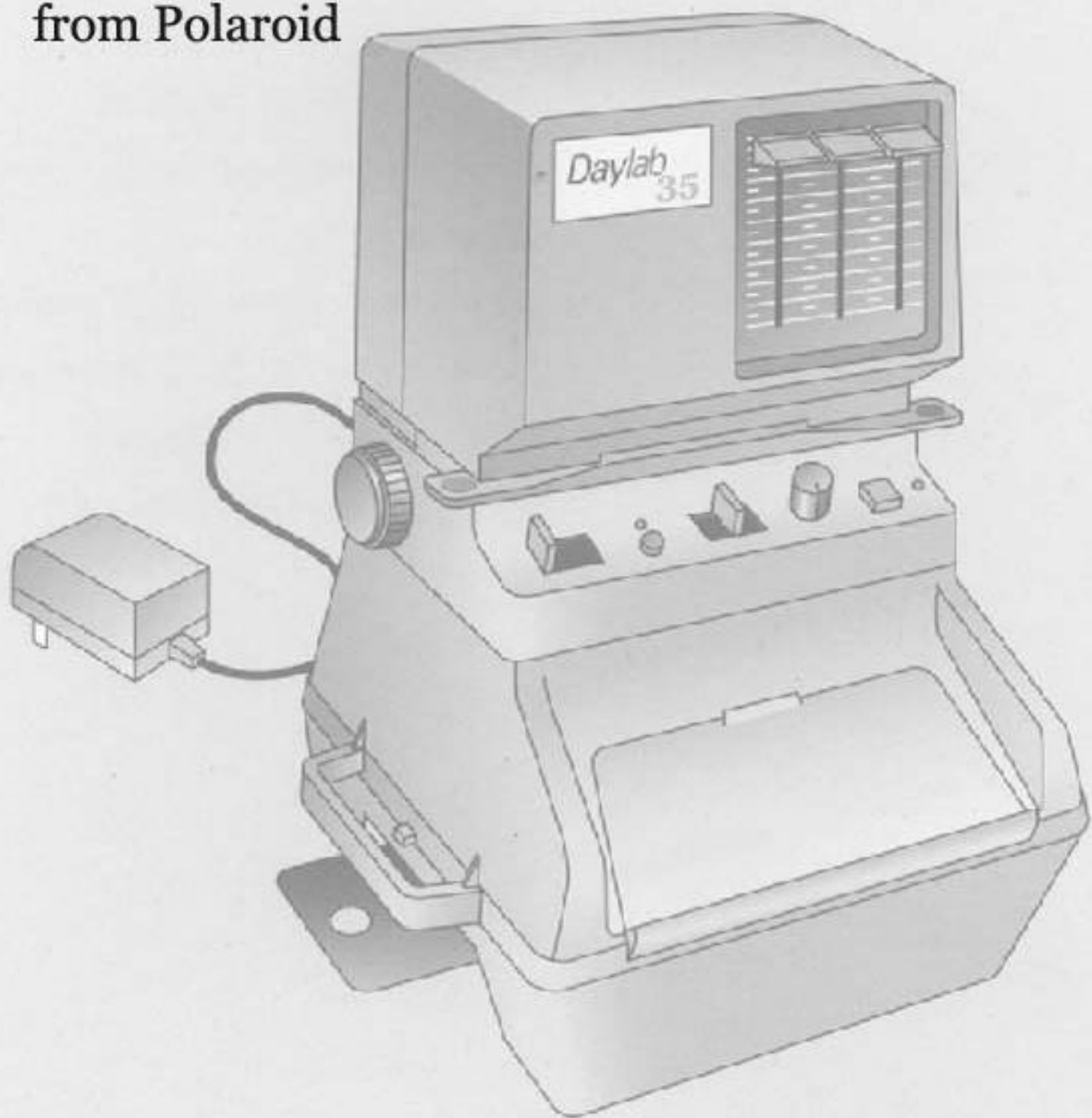

Table of contents

- 1** Introduction
- 2** Loading film
- 3** Connecting the power supply
- 3** Determining the processing time of the film
- 3** Setting the exposure control
- 5** Setting the color-filtration controls
- 6** Preparing to make a print
- 7** Exposing the film
- 7** Processing the film
- 9** Possible problems, causes
- 10** Warranty
- 10** For information or assistance
- 11** FCC Notice (U.S.A. only)
- 11** EMI Notice (Canada)
- 12** Parts and accessories

Illustrations

- Pg 13**, Parts & Film loading
 - Pg 14**, Film Loading, controls & film processing
 - Pg 15**, Trouble shooting
- Refer to reference numbers in text

Introduction

The Daylab 35 Slide Printer allows you to make prints of 35mm slides onto Polaroid 31/4 x 41/4 in. peel-apart instant films.

The Daylab35 is easy to operate and offers such features as preset focusing, automatic exposure control, exposure adjustment, automatic film-development timing, and built-in color filters for creative effects. With the Daylab 35, you can explore a wide range of creative applications, including the Polaroid Emulsion and image Transfer processes.

Contact your Polaroid dealer for additional information.

If you need assistance on how to use the Daylab 35 Slide Printer or Polaroid films, or if you should have film-related questions, please call us toll-free 1-800-343-5000, Mon. Fri., 8 a.m. to 8 p.m. (Eastern Time) from anywhere in the U.S.A. Or, write to the Customer Care Center, Polaroid Corporation, 201 Burlington Road, Bedford, MA 01730.

The numbers throughout the text refer to the Daylab 35 illustrations on the pages at the back of the manual.

Parts (pg 13)

- a Power supply
- b Film-holder dark slide/viewing panel
- c Color-filtration controls
- d Slide carrier
- e Ready indicator
- f START button
- g Exposure-adjustment dial
- h VIEW-OFF-PRINT switch
- i Film-processing-timer button
- j Film-processing-timer indicator
- k Film-type selection switch
- l image-preview door

Note: The dark slide/viewing panel has a dual function. When fully inserted into the film holder, it serves as a dark slide by preventing accidental exposure of your film. Its white surface facilitates image composition when you project the slide image onto it with the VIEW lamp.

Loading film

Remove the base of the Daylab 35 by lifting the exposure unit up. Invert the film holder.

Unlatch and open the film-holder door (2): Pull down both ends of the latch and open the film-holder door (2m).

Before loading film into the film holder, check that the steel rollers are clean. Dirt on the rollers may cause a number of picture problems such as repeated spots and bars on the pictures, poor colors, or jammed film, as explained in *Possible problems, causes*

Hold the film pack by the edges only. Insert the closed end of the pack at an angle (3), then push the pack down into position.

Check that the white leader and processing tabs are free, as shown (4), not caught between the pack and the film chamber.

Close and latch the film-holder door:

Hold the door closed and push the latch up over the end of the film holder (5) so that it snaps into position.,

Caution: Before continuing with the next steps, check the dark slide/viewing panel to be sure that it is inserted all the way into the film holder. If it is not, you risk exposing the film.

The black safety-cover tab (5n) must extend from the film holder. If not, reopen the door, and straighten the safety-cover tab.

Grip the tab firmly, and pull the safety cover straight all the way out of the film holder (6).

When you remove the safety cover, a white leader tab (6o) should protrude from the slot. If it does not, carefully open the door (doing so in dim light) and free the tab. Close and latch the door, with the tab extending outside.

The film holder is now loaded and ready for the first exposure.

Recommended Polaroid instant films, for use with the following Daylab 35 applications:

	<i>Slide copies</i>	<i>Emulsion/Image transfer</i>	<i>Inter-negative</i>
Color applications:			
	669	669	-
	679		
	689		
Black and white applications:			
	664**	-	665

*Use Type 665 positive/negative film to produce a reusable negative of your image to create multiple black-and-white prints.

**Note that the development time of Type 664 film at 75°F (24°C) and above is only 30 sec.

Connecting the power supply

Plug the Daylab 35 power supply (110 125 VAC) into an appropriate electrical outlet and then into the connection on the back of the Daylab 35.

Determining the processing time of the film

Processing times vary for different film types. Also, temperature affects the processing time of your film. Check your film instructions for the recommended processing time so you can select the appropriate film-exposure settings and make any necessary adjustments to the Daylab 35 preset film-processing times. These settings are discussed in detail in the next section, *Setting the exposure controls*.

Setting the exposure controls (7)

On the front of the Daylab 35 are the 4 controls that you need to make an exposure: the film-type selection switch, the VIEW-OFF-PRINT switch, the exposure-adjustment dial, and the START button.

The film type selection switch: The Daylab 35 has three exposure settings, preset for specific Polaroid instant films.

Setting 1 For Type 665 black-and-white positive/negative film with a speed of ISO 75/19°. The Daylab 35 preset film-processing time is 30 seconds.

Setting 2 For Type 669 Polacolor extended-range film with a speed of ISO 80/20°. The preset film-processing time is 60 seconds.

Setting 3: For Polacolor 679, Type 689 ProVivid, and Polapan Pro 100 Type 664 films, with a speed of ISO 100/21°. The preset film-processing time is 90 seconds for Type 679 and 689 films. Type 664 film has a 30-second development time; time the development manually.

4.

The VIEW-OFF-PRINT switch:

VIEW: Select VIEW to compose an image on the dark slide/viewing panel. This setting turns on the lamp that projects your slide image onto the dark slide/viewing panel.

Warning: Never leave your slide under the VIEW lamp longer than necessary. Heat from the lamp can damage your slide. The Daylab 35 has a built-in switch that automatically shuts off the VIEW lamp after approximately 4 minutes. This prevents the lamp from overheating and damaging your slide. To turn the VIEW lamp on again, set the VIEW-OFF-PRINT switch at OFF: then move it back to VIEW.

OFF: After you compose your image, return the switch to OFF until you are ready to make a print. Doing so helps extend the life of the VIEW lamp. When you finish using the Daylab Jr., always return the switch to OFF.

PRINT: Select PRINT when you are ready to make the exposure. When you select PRINT, the ready-indicator light to the right of the START button should be off. You must wait approximately 15 seconds until it glows green before you can press the START button. Note that the built-in flash that exposes the film is not activated until you press the START button. The lamp shuts off automatically following the exposure.

The exposure adjustment dial: The exposure adjustment dial lets you adjust the exposure of your prints. The Daylab 35 has an exposure-correction range with seven settings. Use the "0" setting at the midpoint of the range if you have a properly exposed slide, where no exposure correction is needed. Turning the dial from "0" clockwise in the "+" direction lets you increase the exposure to lighten your printed image. Turning the dial from "0" counterclockwise in the "-" direction lets you reduce the exposure to darken your printed image. For more information see *Possible problems, causes*.

The START button: The START button fires the built-in flash that exposes the film. If you press START and the green ready indicator is not on, the flash does not fire (the ready indicator turns on 15 seconds after you select PRINT with the VIEW-OFF-PRINT switch).

Caution: To prevent accidental film exposure, follow the sequence of steps carefully in *Exposing the film*.

Setting the Color-filtration controls (8)

On the front of the Daylab 35 are three color-filtration controls for correcting color balance and for creating special effects. If you want to adjust the color balance of your print, use the color-filtration controls to add amounts of the three primary colors: cyan, magenta and yellow to your print. Add one color or a combination of two colors at a time.

The filters are scaled so you can measure the amount of filtration for each color. Use "0=" for no filtration. Or, increase the filtration by increments of 5, up to "80," the maximum filtration level.

As you evaluate the color balance of your image to determine what correction it may need, first select a portion of the image that should be neutral or gray to detect any undesirable color cast. Whenever possible, look also at skin tones for improperly balanced color.

To eliminate the undesired color cast from your image, you need to add filtration for the complement of the color (for color correction, refer to the chart, *Correcting prints from co/or slides*).

In color photography, light is broken down into three primary colors: cyan (greenish blue, magenta (reddish purple) and yellow. By pairing these colors in equal amounts, you can create the following secondary colors:

- CYAN + MAGENTA = BLUE
- MAGENTA + YELLOW = RED
- YELLOW + CYAN = GREEN

To add a certain color to your printed image, you must either add that same color with filtration or decrease its complement. Use the chart below to determine what filter or combination of filters you need to correct your image.

Correcting prints from color slides

<i>If you want:</i>	<i>add:</i>	<i>or</i>	<i>subtract:</i>
Less YELLOW	CYAN + MAGENTA		YELLOW
More YELLOW	YELLOW		CYAN + MAGENTA
Less RED (MAGENTA + YELLOW)	CYAN		MAGENTA + YELLOW
More RED	MAGENTA + YELLOW		CYAN
Less MAGENTA	YELLOW + CYAN		MAGENTA
More MAGENTA	MAGENTA		YELLOW + CYAN
Less BLUE (CYAN + MAGENTA)	YELLOW		CYAN + MAGENTA
More BLUE	CYAN + MAGENTA		YELLOW
Less CYAN	MAGENTA + YELLOW		CYAN
More CYAN	CYAN		MAGENTA + YELLOW
Less GREEN (YELLOW + CYAN)	MAGENTA		YELLOW + CYAN
More GREEN	YELLOW + CYAN		MAGENTA

6

Note: As you set the filters to make color adjustments, the Daylab 35 does not show the effects of the adjustments as you preview the image projected on the dark slideviewing panel. Make test exposures to gauge what effects you want to achieve with color filtration.

Note: Adding filtration extends exposure time. Use the exposure-adjustment dial to compensate for these changes. Also note that extending the exposure times can result in further color shift.

Note: Use no more than two filters at any one time.

Note: You can also use the filters to add or subtract tonal values to your black-and-white prints.

Preparing to make a print

Select a slide: The Daylab 35 lets you add creative effects to your slides, but it cannot improve the photographic quality of your original image. Choose a clean, dust-free 35mm slide that is in sharp focus, has an even exposure (neither too light nor too dark and accurately renders the colors of your subject).

Orient your slide on the slide carrier:

Holding the slide carrier with its long edge facing you (the guides that hold the slide in place face upward), lay your slide emulsion-side-up /dull-side-up) on the carrier so that it fits within the guides. Be sure to orient the slide on the carrier so the image is upside down and appears as a mirror image on the dark slide/viewing panel.

Compose your picture: With the slide correctly oriented, insert the slide carrier into the slide carrier slot (9) Set the VIEW-OFF-PPINT switch at VIEW; the viewing light inside the Daylab 35 should now be on. Open the image-preview door to view your image projected onto the dark slideviewing panel (10).

You can move the slide carrier from side to side to center the image on the dark slideviewing panel. Notice, however, that you cannot print the full format of your slide. You lose approximately 1/16 in. from the horizontal dimension of the image.

Also, note that the Daylab 35 has nonadjustable, fixed focusing.

Warning: Never leave your slide under the VIEW lamp longer than necessary. Heat from the lamp can damage your slide.

The Daylab 35 has a built-in switch that automatically shuts off the VIEW lamp after approximately 4 minutes. This prevents the lamp from overheating and damaging your slide. To turn the VIEW lamp on again, set the VIEW-OFF-PRINT switch at OFF; then move it back to VIEW. Caution: After centering your image on the dark slideviewing panel, be sure to close the image-preview door. Leaving the door open while you expose the film fogs the print.

Exposing the film

- 1 Set the film-type selection switch at the setting appropriate for the type of film you are using. See *Setting the exposure controls*.
- 2 Set the exposure-adjustment dial at the setting appropriate for your slide. For a slide image with average lighting conditions, start with the (0) setting.
- 3 Set the VIEW-OFF-PRINT switch at PRINT.
- 4 Set the color filtration controls at the appropriate settings for your slide. You should initially set the 3 color-filtration controls at "0".
- 5 To expose the film, first close the image-preview door (11). Then gently pull the dark slide out of the film holder as far as it will go.
- 6 Wait approximately 15 seconds for the ready-indicator light to turn green. Then press the START button to fire the flash that exposes the film. Press the button gently. The slightest vibration to the Daylab 35 can blur your printed image.
- 7 After exposing the film, gently insert the dark slide/viewing panel back into the film holder, as far as it can go.

Processing the film

Pull the leader tab: Grasp the white leader tab, and pull it straight, all the way out of the film holder (12). This causes a second white tab, a larger processing tab with arrows (12p), to appear. If no processing tab appears, follow the instructions in if no processing tab appears when you pull the leader tab.

Pull the processing tab: Grip the processing tab firmly in the center and pull it straight, in one smooth continuous motion, at moderate speed, all the way out of the film holder (13).

The picture is now developing, so start timing immediately. Press the film-processing-timer button on the front of the Daylab 35. When you press the button, the film-processing-timer indicator starts to glow. Do not disturb the print while the image is developing. Wait until the Daylab 35 beeps (4 times), indicating the preset development time has elapsed (the timer indicator stops glowing).

Note: Refer to *Setting the exposure controls* for detailed information about the three preset development times. These times are set for film development at room temperature (70°F/21°C) When developing the film above or below room temperature, check your film instructions for the development time recommended for that temperature, and use the exposure-adjustment dial to make any exposure adjustments.

After the full development time, separate the print from the negative, starting at the corner nearest the processing tab (14). Do not let the print drop back onto the damp negative. (See *Caution* at the end of this section).

If no processing tab appears when you pull the leader tab: Stop! Do not pull another leader tab. Instead, carefully open the film holder, in dim light, without disturbing the film pack. You can use your fingertip to make sure the pack does not move (15). Take hold of the processing tab that failed to come out, gently pull it all the way out of the film holder (16), and discard it.

While the door is open, check the developer rollers and the processing-tab slot and, if necessary, clean them. See *Cleaning the developer rollers*.

Close and latch the door with the next leader tab extending outside.

If you accidentally pull two leader tabs: Then two processing tabs protrude, at the same time, from the film holder. Both pieces of film will be ruined, and unless you are careful, you may also lose a third picture.

Do not open the film holder. Grip both processing tabs firmly, pull them out together, and discard both pieces of film. This may cause developer to spread inside the film holder. Open the door, and without disturbing the film pack, clean the developer rollers and the slot for the processing tab.

Cleaning the developer rollers: Apply pressure with both thumbs to lift the steel loops and remove the roller assembly (17) from the film holder.

Clean both rollers with a soft, lint-free cloth, dampened with water, if necessary, or hold the roller assembly under running water. As you clean them, rotate both rollers and inspect them. (Note that one roller turns more easily than the other.) Never scrape the rollers with anything metallic, nor with your fingernail. Do not attempt to disassemble the rollers.

Blow any dust or lint out from the film chamber. Also clean the slot for the processing tab (18). To reinsert the roller assembly, slide the rollers into position and, using both hands, press the steel loops down flat.

Caution: The Polaroid instant film process uses a caustic paste. Avoid its contact with skin, eyes and mouth and keep it away from children and animals.

If you get some paste on your skin, wipe it off immediately and wash with water to avoid an alkali burn. If eye or mouth contact occurs, quickly wash the area with plenty of water and see a doctor. Keep discarded materials away from children, animals, clothing and furniture.

Possible problems, causes

An image blurred, out of focus

Most likely cause is:

- Selecting a slide that is not in sharp focus. Use a properly focused image.

A black or blank print

Most likely causes are:

- Forgetting to press the START button to expose the film.
- Forgetting to move the VIEW-OFF-PRINT switch to PRINT before pressing the START button to expose the film. (No exposure will have been made.)
- Leaving the dark slide/viewing panel inserted in the film holder while attempting to make an exposure.

A fogged print (light image or no image at all)

Most likely causes are:

- Opening the image-preview door without first inserting the dark slide/viewing panel into the film holder.
- Leaving the image-preview door open when pressing START to expose the film.
- Using the wrong film-type-selector-switch setting.
- Removing unused film from the film holder without reinserting the black safety cover; then reloading it into the film holder.

A print either too light or too dark

Most likely causes are:

- Using a slide that is overexposed or underexposed. The Daylab 35 cannot enhance an improperly exposed original image.
- Overexposing or underexposing the film. If the print is overexposed, decrease exposure with the exposure adjustment dial by -1 or more, depending on the severity of the overexposure. If underexposed, increase exposure with the exposure-adjustment dial by +1 or more, depending on the severity of the underexposure.

An image printed backwards

The slide is oriented incorrectly on the slide carrier. Be sure that the image projected on the dark slide/viewing panel appears as a mirror image of what you want for your final print.

Repeated white spots (19)

Marks like these result from dirt on the steel rollers of the film holder. Inspect the rollers each time you load film, and clean them whenever necessary.

A curtain-shaped mark or broad streak

If you start to pull the processing tab and then stop or hesitate briefly, a curtain-shaped mark along the print edge appears. If you stop mid-way into the pull, a broad streak results. Always pull the processing tab out in one smooth, continuous motion.

An oblong in the print(20)

This indicates that you did not pull the leader tab all the way out. When you then pulled the processing tab, the leader tab retracted into the film holder, thus spoiling the picture. Always pull the leader tab all the way out of the film holder.

Underdeveloped edges or corners (21)

These are usually caused by pulling the processing tab out at an angle. This prevents the developer from being spread evenly over the image area. With color film, pulling the tab at an angle generally results in orange-red marks along the edge of the print.

Many small white specks (22)

These indicate that you pulled the processing tab too swiftly. Pulling the tab too fast can also cause pink lines, streaks or blotches on color prints. Pull the processing tab a little less rapidly, in one smooth uninterrupted motion.

A muddy looking print

The print was not allowed to develop long enough before separation from the negative. Develop pictures for the full time recommended in the film instructions. Underdeveloped color prints tend to be a brownish pink.

Warranty

Your Daylab 35 is guaranteed against defects in materials and workmanship for one full year from the date of original purchase. During this period, any such defects will be remedied without charge, except for transportation costs. The warranty excludes damage resulting from normal wear, mishandling or accident, and a charge will be made for such repairs. The warranty excludes the viewing bulb. **This warranty excludes consequential damage. Some jurisdictions do not allow the limitation or exclusion of consequential damages, so the foregoing may not apply to you.**

For information or assistance

For further information or warranty assistance with the Daylab 35 or for information or assistance with Polaroid photographic processes, call Polaroid Corporation, toll-free at 1-800-343-5000, Mon.-Fri., 8 AM to 8 PM (Eastern Time).

For service: Before returning the Daylab 35 for service, contact Polaroid Corporation at 1-800-343-5000 for shipping instructions and service information.

Polaroid Corporation provides referral and shipping assistance with the Daylab 35 with the consent of Pfaff Manufacturing Inc. and solely as a service for Polaroid customers. This service shall not be construed to warrant or represent the function, fitness, workmanship or design of any non-Polaroid products.

FCC Notice (U.S.A. only)

This equipment has been tested and found to comply with the limits for a Class B digital device, pursuant to Part 15 of the FCC Rules. These limits are designed to provide reasonable protection against harmful interference when the equipment is operated in a residential installation. This equipment generates, uses, and can radiate radio frequency energy and, if not installed and used in accordance with the instruction manual, may cause harmful interference to radio communications. However, there is no guarantee that interference will not occur in a particular installation. If this equipment does cause harmful interference to radio or television reception, which can be determined by turning the equipment off and on, the user is encouraged to try to correct the interference by one or more of the following measures:

- Reorient or relocate the receiving antenna of the radio or television.
- increase the separation between the equipment and the receiver.
- Connect the equipment to an outlet on a circuit different from that to which the receiver is connected.
- Consult the dealer for help.

Note: Changes or modifications not expressly approved by the party responsible for compliance could void the user's authority to operate this equipment.

EMI Notice (Canada)

This Class B digital apparatus meets all requirements of the Canadian Interference-Causing Equipment Regulations.

Cet appareil numérique de la classe B respecte toutes les exigences du Règlement sur le matériel brouilleur du Canada.

Parts and Accessories

To order Daylab 35 parts or accessories, call Polaroid Corporation toll-free at 1-800-343-5000, Mon - Fri, 8 AM to 8 PM (Eastern Time). Listed below are parts and accessories for the Daylab 35 and the Daylab 35 Plus.

<i>Item</i>	<i>Order number</i>	<i>Description</i>
Daylab 35 Slide Printer	114723	Complete slide-printing system for use with Polaroid 31/4 x 41/4 instant peel-apart films; includes: Slide printer & 31/4 x 41/4 film-holder Power supply
Polaroid Emulsion/Image Transfer Kit	619769	Includes: 2 heavy-duty trays Timer Thermometer Print tongs Roller Mylar sheet Contact paper Watercolor paper 6 blank watercolor greeting cards with envelopes Image- and Emulsion Transfer Guide
35mm to Transfers Guide	1 F51 25	A guide to creating transfers from 35mm slides

1

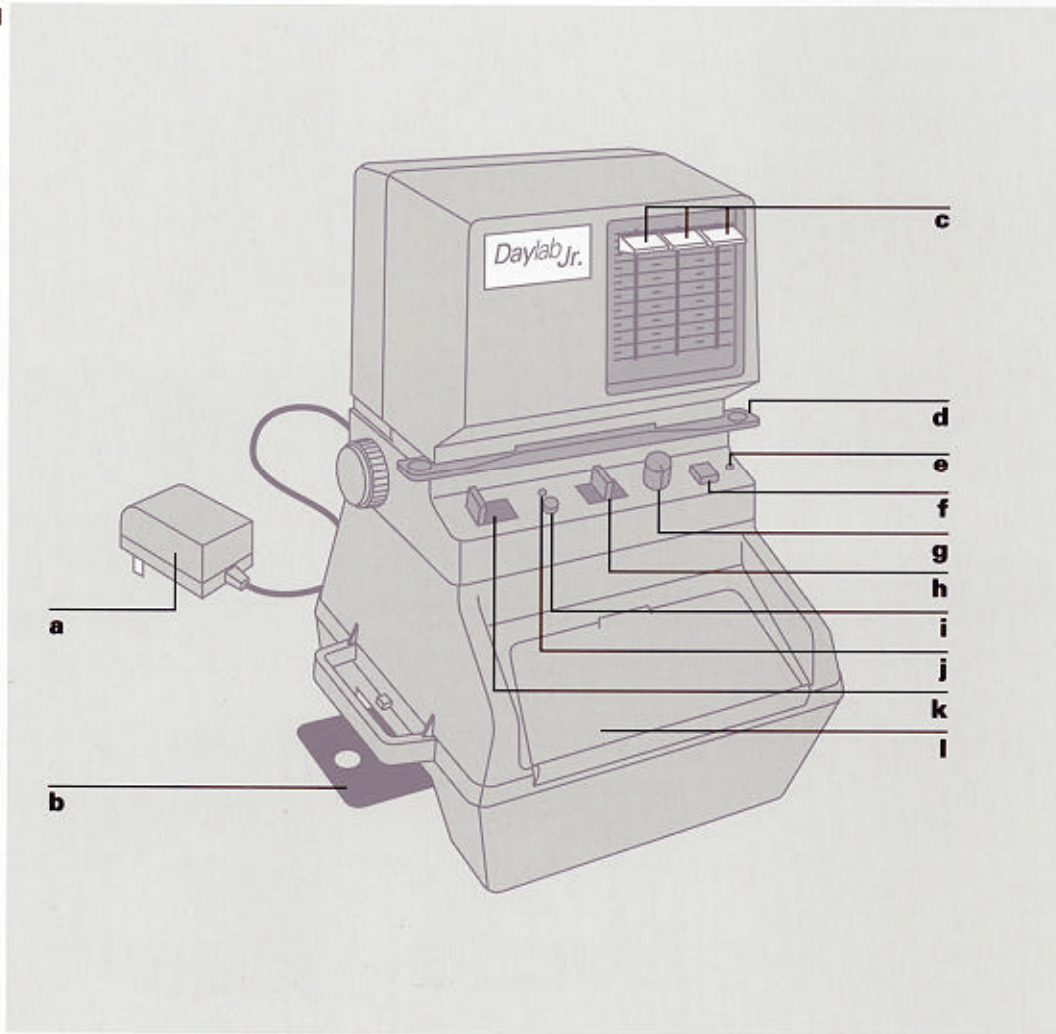

2

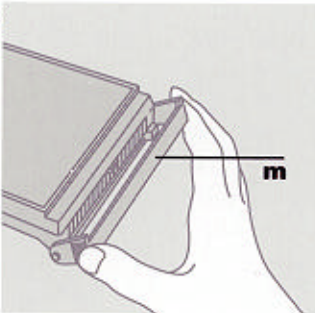

3

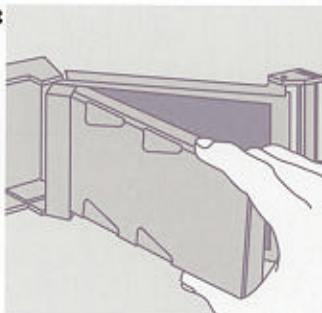

4

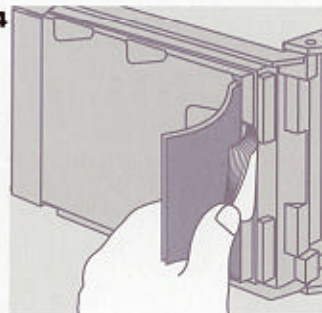

15

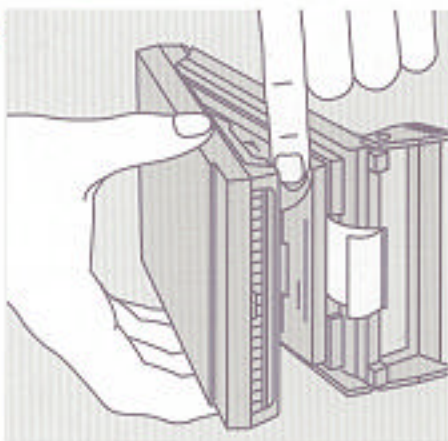

16

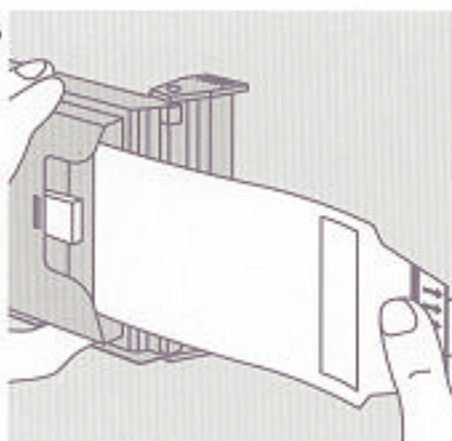

17

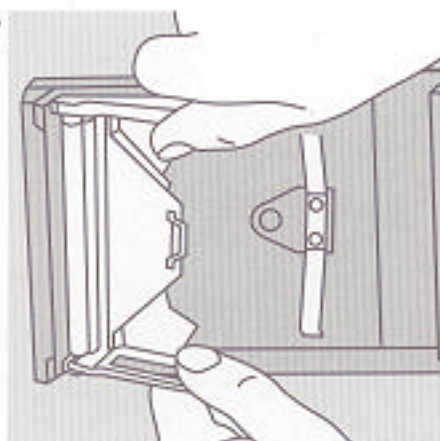

18

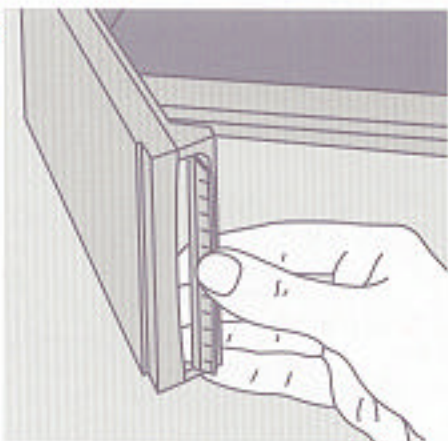

19



20



21



22



